

RF PIN Diode

Mechanical Data

Case: Plastic case (SOD 523)

Weight: 1.5 mg

Cathode Band Color: Laser marking

Packaging Codes/Options:

GS08 / 3 k per 7" reel (8 mm tape), 3 k/Box

Description

Characterized by low reverse Capacitance the PIN Diode BAR64V-02V was designed for RF signal switching and tuning. As a function of the forward bias current the forward resistance (rf) can be adjusted over a wide range. A long carrier life time

offers low signal distortion for signals over 10 MHz up to 3 GHz. Typical applications for this PIN Diode are switches and attenuators in wireless, mobile and TV-systems.

Features

- High reverse Voltage
- Space saving SOD523 package with low series inductance
- Small reverse capacitance
- High breakdown voltage

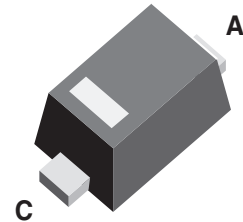

16863

Applications

- For frequency up to 3 GHz
- RF-signal tuning
- Signal attenuator and switches
- Mobile , wireless and TV-Applications

Parts Table

Part	Ordering code	Marking	Remarks	Package
BAR64V-02V	BAR64V-02V-GS08	D	Tape and Reel	SOD523

Absolute Maximum Ratings

T_{amb} = 25 °C, unless otherwise specified

Parameter	Test condition	Sub type	Symbol	Value	Unit
Reverse voltage			V _R	100	V
Forward current			I _F	100	mA
Junction temperature			T _j	150	°C
Storage temperature range			T _{stg}	- 55 to + 150	°C

Maximum Thermal Resistance

T_{amb} = 25 °C, unless otherwise specified

Parameter	Test condition	Symbol	Value	Unit
Junction soldering point		R _{thJS}	100	K/W

Electrical Characteristics

T_{amb} = 25 °C, unless otherwise specified

Parameter	Test condition	Sub type	Symbol	Min	Typ.	Max	Unit
Reverse voltage	I _R = 10 μA		V _R	100			V

Parameter	Test condition	Sub type	Symbol	Min	Typ.	Max	Unit
Reverse current	$V_R = 50\text{ V}$		I_R			50	nA
Forward voltage	$I_F = 50\text{ mA}$		V_F			1.1	V
Diode capacitance	$f = 1\text{ MHz}, V_R = 0$		C_D		0.5		pF
	$f = 1\text{ MHz}, V_R = 1\text{ V}$		C_D		0.37	0.5	pF
	$f = 1\text{ MHz}, V_R = 20\text{ V}$		C_D		0.23	0.35	pF
Forward resistance	$f = 100\text{ MHz}, I_F = 1\text{ mA}$		r_f		10	20	Ω
	$f = 100\text{ MHz}, I_F = 10\text{ mA}$		r_f		2.1	3.8	Ω
	$f = 100\text{ MHz}, I_F = 100\text{ mA}$		r_f		1	1.35	Ω
Charge carrier life time	$I_F = 10\text{ mA}, I_R = 6\text{ mA}, I_R = 3\text{ mA}$		t_{rr}		1.6		μs

Typical Characteristics ($T_{amb} = 25^\circ\text{C}$ unless otherwise specified)

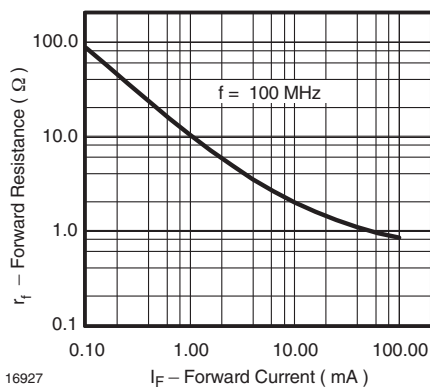

Figure 1. Forward Resistance vs. Forward Current

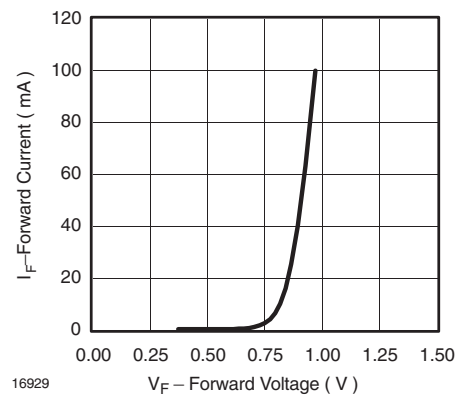

Figure 3. Forward Current vs. Forward Voltage

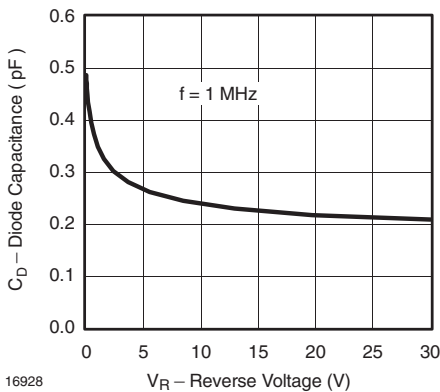
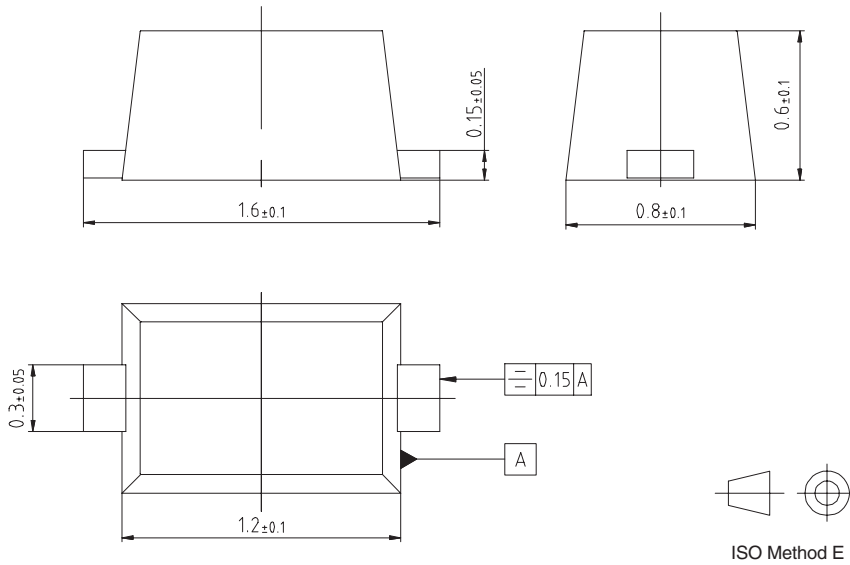

Figure 2. Diode Capacitance vs. Reverse Voltage

Package Dimensions in mm



16864

Ozone Depleting Substances Policy Statement

It is the policy of **Vishay Semiconductor GmbH** to

1. Meet all present and future national and international statutory requirements.
2. Regularly and continuously improve the performance of our products, processes, distribution and operating systems with respect to their impact on the health and safety of our employees and the public, as well as their impact on the environment.

It is particular concern to control or eliminate releases of those substances into the atmosphere which are known as ozone depleting substances (ODSs).

The Montreal Protocol (1987) and its London Amendments (1990) intend to severely restrict the use of ODSs and forbid their use within the next ten years. Various national and international initiatives are pressing for an earlier ban on these substances.

Vishay Semiconductor GmbH has been able to use its policy of continuous improvements to eliminate the use of ODSs listed in the following documents.

1. Annex A, B and list of transitional substances of the Montreal Protocol and the London Amendments respectively
2. Class I and II ozone depleting substances in the Clean Air Act Amendments of 1990 by the Environmental Protection Agency (EPA) in the USA
3. Council Decision 88/540/EEC and 91/690/EEC Annex A, B and C (transitional substances) respectively.

Vishay Semiconductor GmbH can certify that our semiconductors are not manufactured with ozone depleting substances and do not contain such substances.

We reserve the right to make changes to improve technical design and may do so without further notice.

Parameters can vary in different applications. All operating parameters must be validated for each customer application by the customer. Should the buyer use Vishay Semiconductors products for any unintended or unauthorized application, the buyer shall indemnify Vishay Semiconductors against all claims, costs, damages, and expenses, arising out of, directly or indirectly, any claim of personal damage, injury or death associated with such unintended or unauthorized use.

Vishay Semiconductor GmbH, P.O.B. 3535, D-74025 Heilbronn, Germany
Telephone: 49 (0)7131 67 2831, Fax number: 49 (0)7131 67 2423